

40x40x56mm

Model A

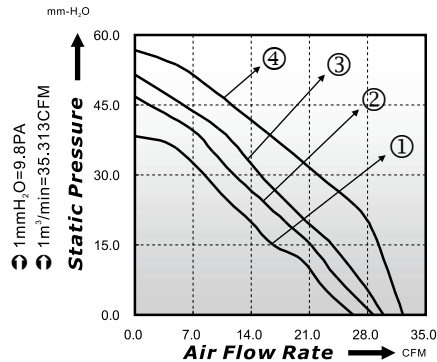

P-Q Curve (At Rated Voltage)



Dimensions Drawing

Unit: (mm)

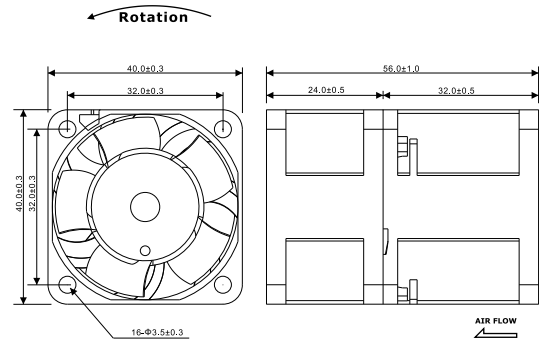

Model No	Bearing (*)	Rated Voltage (VDC)	Rated Current (A)	Power Consumption (Watts)	Speed (rpm)	Air Flow (CFM)	Static Pressure (mmH ₂ O)	Noise (dBA)	Curve
ED04056-12LB	●	12	1.00	12.00	11000/10000	26.25	38.40	57.8	1
ED04056-12MB	●	12	1.25	15.00	13300/12300	28.68	46.72	60.7	2
ED04056-12HB	●	12	1.50	18.00	13900/12700	29.95	51.55	61.4	3
ED04056-12HHB	●	12	1.80	21.60	15000/13500	32.22	56.72	63.65	4

* Bearing Type: ○ Sleeve ● Two Ball ⊙ Hydro-Dynamic